

# **The AASM Manual** *for the Scoring of Sleep* **and Associated Events**

Rules, Terminology and Technical Specifications



**CONRAD IBER, MD, SONIA ANCOLI-ISRAEL, PhD, ANDREW L. CHESSON JR., MD AND  
STUART F. QUAN, MD FOR THE AMERICAN ACADEMY OF SLEEP MEDICINE**

**AMERICAN ACADEMY OF SLEEP MEDICINE, WESTCHESTER, IL**

Copyright 2007 American Academy of Sleep Medicine, 1 Westbrook Corporate Center, Suite 920, Westchester, IL 60154, U.S.A

Copies of the manual are available from the American Academy of Sleep Medicine in the U.S.A.

All rights reserved. Unless authorized in writing by the AASM, no portion of this book may be reproduced or used in a manner inconsistent with the copyright. This applies to unauthorized reproductions in any form, including computer programs.

Correspondence regarding copyright permissions should be directed to the Executive Director, American Academy of Sleep Medicine, 1 Westbrook Corporate Center, Suite 920, Westchester, IL 60154, U.S.A. Translations to other languages must be authorized by the American Academy of Sleep Medicine, U.S.A.

#### Recommended Citations

(Numerical)

Iber C, Ancoli-Israel S, Chesson A, and Quan SF for the American Academy of Sleep Medicine. The AASM Manual for the Scoring of Sleep and Associated Events: Rules, Terminology and Technical Specifications, 1<sup>st</sup> ed.: Westchester, Illinois: American Academy of Sleep Medicine, 2007.

(Alphabetical)

Iber C, Ancoli-Israel S, Chesson A, and Quan SF for the American Academy of Sleep Medicine. The AASM Manual for the Scoring of Sleep and Associated Events: Rules, Terminology and Technical Specifications, 1<sup>st</sup> ed.: Westchester, Illinois: American Academy of Sleep Medicine, 2007.

Library of Congress Control Number: PRE000000078

## TABLE OF CONTENTS

	<b>pages</b>
Contributors and Acknowledgements	6
Preface	9
Development Process	11
 <b>Scoring Manual</b>	
I. Key	15
II. Parameters to Be Reported for Polysomnography	17
III. Technical and Digital Specifications	19
IV. Visual Rules	23
Visual Rules for Adults	23
Visual Rules for Children	32
V. Arousal Rule	37
VI. Cardiac Rules	39
VII. Movement Rules	41
VIII. Respiratory Rules	45
Respiratory Rules for Adults	45
Respiratory Rules for Children	48
IX. Procedural Notes	51
X. Glossary of Terms	59

## I. KEY

### 1. RULES

- [RECOMMENDED] These rules are recommended for the routine scoring of polysomnography.
- [ALTERNATIVE] These are rules that may be used as alternatives to the recommended rules at the discretion of the clinician or investigator.
- [OPTIONAL] These are suggested rules for uncommonly encountered events, events not known to have physiologic significance or events for which there was no consensus decision. Scoring may be performed at the discretion of the clinician or investigator.

### 2. PROCEDURAL NOTES

- [STANDARD] Recommendation based on level 1 evidence or overwhelming level 2 evidence.
- [GUIDELINE] Recommendation based on level 2 evidence or a consensus of level 3 evidence.
- [CONSENSUS] Recommendation with less evidence than guideline for which agreement was reached in a standardized consensus process based on available information.
- [ADJUDICATION] Recommendation from the steering committee based on all available information. Adjudication was only performed a) when there was insufficient evidence and no consensus agreement or b) in conjunction with task force leaders on issues regarding minor clarifications and additions to rules.

## II. PARAMETERS TO BE REPORTED FOR POLYSOMNOGRAPHY

### 1. POLYSOMNOGRAPHY

#### A. Parameters

- |                        |               |
|------------------------|---------------|
| 1) EEG derivations     | [RECOMMENDED] |
| 2) EOG derivations     | [RECOMMENDED] |
| 3) Chin EMG            | [RECOMMENDED] |
| 4) Leg EMG derivations | [RECOMMENDED] |
| 5) Airflow parameters  | [RECOMMENDED] |
| 6) Effort parameters   | [RECOMMENDED] |
| 7) Oxygen saturation   | [RECOMMENDED] |
| 8) Body position       | [RECOMMENDED] |

#### B. Sleep Scoring Data

- |  |               |
|--|---------------|
| 1) Lights out clock time (hr:min)                                      | [RECOMMENDED] |
| 2) Lights on clock time (hr:min)                                       | [RECOMMENDED] |
| 3) Total sleep time (TST; in min)                                      | [RECOMMENDED] |
| 4) Total recording time (“lights out” to “lights on” in min)           | [RECOMMENDED] |
| 5) Sleep latency (SL; lights out to first epoch of any sleep in min)   | [RECOMMENDED] |
| 6) Stage R latency (sleep onset to first epoch of Stage R in min)      | [RECOMMENDED] |
| 7) Wake after sleep onset (WASO; Stage W during B4, minus B5, in min). | [RECOMMENDED] |
| 8) Percent sleep efficiency (B3/B4)x100                                | [RECOMMENDED] |
| 9) Time in each stage (min)  | [RECOMMENDED] |
| 10) Percent of TST in each stage (B9 values/B3)x100                    | [RECOMMENDED] |

*Note: Wake after sleep onset includes all wake activity, including wake out of bed.*

#### C. Arousal Events

- |                                      |               |
|--------------------------------------|---------------|
| 1) The number of arousals            | [RECOMMENDED] |
| 2) The arousal index (ArI; C1x60/B3) | [RECOMMENDED] |

#### D. Respiratory Events

- |  |               |
|--|---------------|
| 1) Number of obstructive apneas  | [RECOMMENDED] |
| 2) Number of mixed apneas  | [RECOMMENDED] |
| 3) Number of central apneas  | [RECOMMENDED] |
| 4) Number of hypopneas   | [RECOMMENDED] |
| 5) Number of apneas + hypopneas  | [RECOMMENDED] |
| 6) Apnea index (AI; (D1+D2+D3)x60/B3)                                  | [RECOMMENDED] |
| 7) Hypopnea index (HI; D4x60/B3)                                       | [RECOMMENDED] |
| 8) Apnea + Hypopnea index (AHI; D5x60/B3)                              | [RECOMMENDED] |
| 9) Respiratory effort related arousals, total number                   | [OPTIONAL]    |
| 10) Respiratory effort related arousal index (D9x60/B3)                | [OPTIONAL]    |
| 11) Oxygen desaturations $\geq 3\%$ or $\geq 4\%$ , total number       | [OPTIONAL]    |
| 12) Oxygen desaturation index $\geq 3\%$ or $\geq 4\%$ (DI; D11x60/B3) | [OPTIONAL]    |
| 13) Continuous oxygen saturation, mean value                           | [RECOMMENDED] |
| 14) Minimum oxygen saturation during sleep                             | [RECOMMENDED] |

- |  |               |
|--|---------------|
| 15) Occurrence of hypoventilation (yes / no)         | [OPTIONAL]    |
| 16) Occurrence of Cheyne Stokes breathing (yes / no) | [RECOMMENDED] |

*Notes:*

1. For oxygen desaturation, percent time spent below a given threshold may be reported at the discretion of the investigator.
2. In adults, the choice of hypopnea definition (recommended, VII.4A or alternative, VII.4B) should be specified in D4, D5, D7, D8.

**E. Cardiac Events**

- |  |               |
|--|---------------|
| 1) Average heart rate during sleep     | [RECOMMENDED] |
| 2) Highest heart rate during sleep     | [RECOMMENDED] |
| 3) Highest heart rate during recording | [RECOMMENDED] |

Occurrence of the following arrhythmias (yes/no). If present, list arrhythmia and heart rate or duration of pause.

- |   |               |
|---|---------------|
| 4) Bradycardia; report lowest heart rate observed                     | [RECOMMENDED] |
| 5) Asystole; report longest pause observed                            | [RECOMMENDED] |
| 6) Sinus tachycardia during sleep; report highest heart rate observed | [RECOMMENDED] |
| 7) Narrow complex tachycardia; report highest heart rate observed     | [RECOMMENDED] |
| 8) Wide complex tachycardia; report highest heart rate observed       | [RECOMMENDED] |
| 9) Atrial fibrillation  | [RECOMMENDED] |

Occurrence of the other arrhythmias (yes/no).

- |                                 |               |
|---------------------------------|---------------|
| 10) If present, list arrhythmia | [RECOMMENDED] |
|---------------------------------|---------------|

**F. Movement Events**

- |  |               |
|--|---------------|
| 1) Number of periodic limb movements of sleep (PLMS)               | [RECOMMENDED] |
| 2) Number of periodic limb movements of sleep (PLMS) with arousals | [RECOMMENDED] |
| 3) PLMS index (PLMSI; F1x60/B3)                                    | [RECOMMENDED] |
| 4) PLMS arousal index (PLMSArI; F2x60/B3)                          | [RECOMMENDED] |

**G. Summary Statements**

- |  |               |
|--|---------------|
| 1. Findings related to sleep diagnoses | [RECOMMENDED] |
| 2. EEG abnormalities                   | [RECOMMENDED] |
| 3. ECG abnormalities                   | [RECOMMENDED] |
| 4. Behavioral observations             | [RECOMMENDED] |
| 5. Sleep hypnogram                     | [OPTIONAL]    |

### III. TECHNICAL AND DIGITAL SPECIFICATIONS

#### 1. SPECIFICATIONS

##### A. Digital Specifications for Routine PSG Recordings (Notes)

[RECOMMENDED]

Maximum Electrode Impedances	5 K $\Omega$ <sup>1</sup>	
Minimum Digital Resolution	12 bits per sample	
<b>Sampling Rates</b>	<b>Desirable</b>	<b>Minimal</b>
EEG	500 Hz <sup>2</sup>	200 Hz <sup>3</sup>
EOG	500 Hz <sup>4</sup>	200 Hz
EMG	500 Hz <sup>5</sup>	200 Hz
ECG	500 Hz <sup>6</sup>	200 Hz
Airflow	100 Hz	25 Hz
Oximetry	25 Hz <sup>7</sup>	10 Hz
Nasal Pressure	100 Hz <sup>8</sup>	25 Hz
Esophageal Pressure	100 Hz	25 Hz
Body Position	1 Hz	1 Hz
Snoring Sounds	500 Hz <sup>9</sup>	200 Hz
Rib Cage and Abdominal Movements	100 Hz <sup>10</sup>	25 Hz
<b>Routinely Recorded Filter Settings</b>	<b>Low Frequency Filter</b>	<b>High Frequency Filter<sup>11</sup></b>
EEG	0.3 Hz	35 Hz <sup>3</sup>
EOG	0.3 Hz	35 Hz
EMG	10 Hz <sup>5</sup>	100 Hz <sup>5</sup>
ECG	0.3 Hz <sup>12</sup>	70 Hz
Respiration	0.1 Hz	15 Hz
Snoring	10 Hz	100 Hz

*Notes:*

1. This applies to measured EEG and EOG electrode impedance. Electrode impedances should be rechecked during a recording when any pattern that might be artifactual appears.
2. For EEG, 500 Hz could improve resolution of spikes in the EEG and better maintain details of the waveform.
3. For more detailed EEG analysis, sampling rate and high frequency filter settings may be increased. In these circumstances, the sampling rate should be at least 3 times the high frequency filter settings.
4. For EOG, using the 500 Hz desirable EEG sampling rate also allows the reflection of the EEG in this lead as an EEG backup and may better define some artifacts in these leads.
5. This applies to submental and leg EMG. Higher sampling rates better define waveforms; while the waveform itself is not an issue, a better-defined waveform can help avoid amplitude attenuation as the envelope of the rapidly oscillating signal is read and interpreted.
6. For ECG, 500 Hz can better define pacemaker spikes and ECG waveforms, however pacemaker spikes can be seen at 200 Hz and the evaluation of cardiac ischemia by ECG waveform is not a usual PSG issue. Higher frequencies may be required for complex waveform analysis and research applications.
7. For oximetry, 25 Hz is desirable to assist with artifact rejection.
8. For nasal pressure transducer technology (especially with settings which identify snoring occurring on top of the airflow wave form), this higher frequency may be of benefit for better definition of flattening, plateauing, and/or fluttering in the wave airflow form.
9. For snoring sound, 500 Hz can better define amplitude variation by clearer waveforms with more accurate amplitude determination as the envelope of the rapidly oscillating signal is interpreted, (as for EMG). If a preprocessing of snoring results in a continuous sound loudness level or in a sound intensity level, then a much lower sampling rate is acceptable. That sampling rate is not specified because it depends on the preprocessing of the sound in order to produce loudness.
10. For rib cage and abdominal movements using inductance plethysmography, cardiogenic oscillations can be better seen and may result in better artifact assessment.
11. To accommodate older equipment, filter settings in the range of 30-35 Hz may be used to comply with the above recommendations of 35 Hz. This applies most specifically in the context of EEG and EOG high filter settings.
12. For ECG, low frequency settings and wide bandwidth minimizes distortion in a 12 lead ECG; however in PSG recording for single-channel modified lead II used for identifying basic heart rates and dysrhythmias, it may not be as necessary. Advanced cardiac assessment may be more optimal using an LFF of 0.3 Hz for slower parts of the cardiac cycle. The channel is susceptible to artifacts at this setting due to patient movement, perspiration, muscle activity and electrode displacement with more sweat artifact, which is a common problem in the laboratory. It is less likely a problem using standard ECG leads with good contact and stability of application than using EEG leads for cardiac monitoring.

General note: in the absence of clear preferences, there is consensus to use similar settings among leads to simplify technical implementation.

## B. Digital PSG Recording Features

*Digital systems must include the following features:*

- 1) A toggle switch permitting visual (on-screen) standard negative 50  $\mu$ V DC calibration signal for all channels to demonstrate polarity, amplitude and time constant settings for each recorded parameter [RECOMMENDED]
- 2) A separate 50/60 Hz filter control for each channel [RECOMMENDED]
- 3) The capability of selecting sampling rates for each channel [RECOMMENDED]
- 4) A method of measuring actual individual electrode impedance against a reference (the latter may be the sum of all other applied electrodes) [RECOMMENDED]
- 5) The capability of retaining and viewing the data in the exact manner in which it was recorded by the attending technologist (i.e., retain and display all derivation changes, sensitivity adjustments, filter settings, temporal resolution) [RECOMMENDED]
- 6) The capability of retaining and viewing the data in the exact manner it appeared when it was scored by the scoring technologist (i.e., retain and display all derivation changes, sensitivity adjustments, filter settings, temporal resolution) [RECOMMENDED]
- 7) A filter design for data collection which functionally simulates or replicates conventional (analog-style) frequency response curves rather than removing all activity and harmonics within the specified bandwidth [RECOMMENDED]

*Digital systems should include the following features:*

- 8) An electrode selector process with the flexibility for choosing and/or changing electrode input signal derivations without relying on a common reference electrode [OPTIONAL]

## C. Rules for PSG Display and Display Manipulation

*Systems must include the following PSG features:*

- 1) Resolution of a digital screen and video card must be at least 1600 x 1200 for display and scoring of raw PSG data [RECOMMENDED]
- 2) Histogram with stage, respiratory events, leg movement events, O<sub>2</sub> saturation, and arousals, with cursor positioning on histogram and ability to jump to the page [RECOMMENDED]
- 3) Ability to view a screen on a time scale ranging from the entire night to windows as small as 5 seconds [RECOMMENDED]
- 4) Recorded video data must be synchronized with PSG data and have an accuracy of at least one video frame per second [RECOMMENDED]

*Systems should include the following PSG features:*

- 5) Page automatic turning and automatic scrolling [OPTIONAL]
- 6) Channel off control key or toggle [OPTIONAL]
- 7) Channel invert control key or toggle [OPTIONAL]
- 8) Change order of channel by click and drag [OPTIONAL]
- 9) Display setup profiles (including colors) which may be activated at any time [OPTIONAL]
- 10) Fast Fourier Transformation or spectral analysis on specifiable interval (omitting segments marked as data artifact) [OPTIONAL]



#### D. Digital Analysis of PSG

*Digital sleep systems must include the ability to:*

- 1) Identify whether sleep stage scoring was performed visually or computed by the system [RECOMMENDATION]

*Digital sleep systems should include the capability to turn off and on, as demanded, highlighting for:*

- 2) Patterns identifying sleep stage decisions (for example sleep spindle, K complex, alpha, delta) [OPTIONAL]
- 3) Patterns identifying the respiratory analysis (for example apneas, hypopneas, desaturations) [OPTIONAL]
- 4) Patterns identifying the movement analysis (for example PLMs) [OPTIONAL]

## IV. VISUAL RULES

### VISUAL RULES FOR ADULTS

#### 1. TECHNICAL SPECIFICATIONS

##### A. Electroencephalogram (EEG)

1) The recommended derivations are:

[RECOMMENDED]

- a.  $F_4-M_1$
- b.  $C_4-M_1$
- c.  $O_2-M_1$

Backup electrodes should be placed at  $F_3$ ,  $C_3$ ,  $O_1$  and  $M_2$  to allow display of  $F_3-M_2$ ,  $C_3-M_2$  and  $O_1-M_2$  if electrodes malfunction during the study.

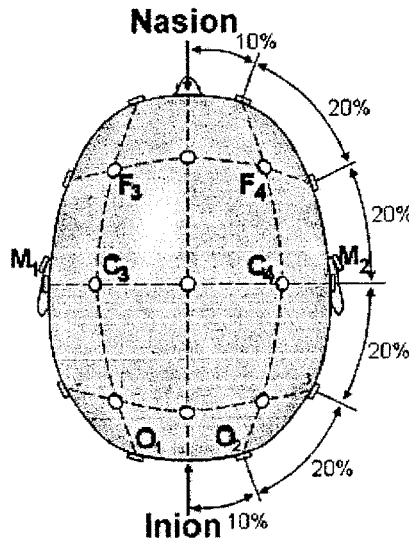

2) Alternative acceptable derivations are:

[ALTERNATIVE]

- a.  $F_z-C_z$
- b.  $C_z-O_z$
- c.  $C_4-M_1$

Backup electrodes should be placed at  $F_{pz}$ ,  $C_3$ ,  $O_1$ , and  $M_2$  to allow substitution of  $F_{pz}$  for  $F_z$ ,  $C_3$  for  $C_z$  or  $C_4$ ,  $O_1$  for  $O_z$  and  $M_2$  for  $M_1$  if electrodes malfunction during the study.

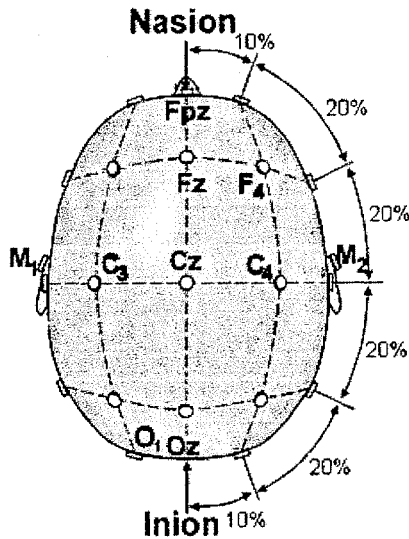

3) EEG electrode position is determined by International 10-20 System

[RECOMMENDED]

Note:

1. A minimum of 3 EEG derivations are required in order to sample activity from the frontal, central, and occipital regions.
2.  $M_1$  and  $M_2$  refer to the left and right mastoid processes.

## B. Electrooculogram (EOG)

1) The recommended EOG derivations are:

[RECOMMENDED]

- a.  $E_1-M_2$  ( $E_1$  is placed 1 cm below the left outer canthus)
- b.  $E_2-M_2$  ( $E_2$  is placed 1 cm above the right outer canthus)

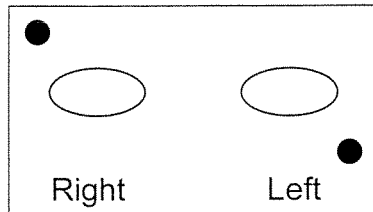

2) Alternative acceptable derivations are:

[ALTERNATIVE]

- a.  $E_1-F_{pz}$  ( $E_1$  is placed 1 cm below and 1 cm lateral to the outer canthus of the left eye)
- b.  $E_2-F_{pz}$  ( $E_2$  is placed 1 cm below and 1 cm lateral to the outer canthus of the right eye)

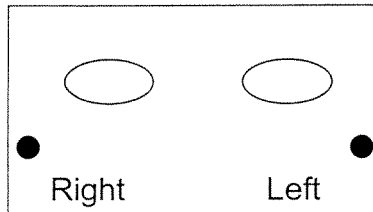

Note: The alternative derivations record the direction of eye movements, i.e. vertical movements will show in-phase deflections and horizontal eye movements out-of-phase deflections.

## C. Electromyogram (EMG)

[RECOMMENDED]

1) Three electrodes should be placed to record chin EMG:

- a. One in the midline 1 cm above the inferior edge of the mandible
- b. One 2 cm below the inferior edge of the mandible and 2 cm to the right of the midline
- c. One 2 cm below the inferior edge of the mandible and 2 cm to the left of the midline

2) The standard chin EMG derivation consists of either of the electrodes below the mandible referred to the electrode above the mandible. The other inferior electrode is a backup electrode to allow for continued display of EMG activity if 1 of the primary electrodes malfunctions.

## 2. SCORING OF SLEEP STAGES

[RECOMMENDED]

### A. Stages of Sleep

1) The following terminology is recommended for the stages of sleep:

- a. Stage W (Wakefulness)
- b. Stage N1 (NREM 1)
- c. Stage N2 (NREM 2)
- d. Stage N3 (NREM 3)
- e. Stage R (REM)

Note: Stage N3 represents slow wave sleep and replaces the R & K nomenclature of stage 3 and stage 4 sleep.

### B. Scoring by Epochs

[RECOMMENDED]

- 1) Score sleep stages in 30 second sequential epochs commencing at the start of the study.
- 2) Assign a stage to each epoch.
- 3) If 2 or more stages coexist during a single epoch, assign the stage comprising the greatest portion of the epoch.

### 3. STAGE W

[RECOMMENDED]

#### Definitions

**Alpha rhythm:** Trains of sinusoidal 8-13 Hz activity recorded over the occipital region with eye closure, attenuating with eye opening.

**Eye blinks:** Conjugate vertical eye movements at a frequency of 0.5-2 Hz present in wakefulness with the eyes open or closed.

**Reading eye movements:** Trains of conjugate eye movements consisting of a slow phase followed by a rapid phase in the opposite direction as the subject reads.

**Rapid eye movements (REM):** Conjugate, irregular, sharply peaked eye movements with an initial deflection usually lasting <500 msec. While rapid eye movements are characteristic of stage R sleep, they may also be seen in wakefulness with eyes open when subjects scan the environment.

#### Rules

**A. Score epochs as stage W when more than 50% of the epoch has alpha rhythm over the occipital region.**

**B. Score epochs without visually discernable alpha rhythm as stage W if any of the following are present:**

- 1) Eye blinks at a frequency of 0.5-2 Hz
- 2) Reading eye movements
- 3) Irregular conjugate rapid eye movements associated with normal or high chin muscle tone

#### Notes:

1. Stage W represents the waking state, ranging from full alertness through early stages of drowsiness. Electrophysiological and psychophysiological markers of drowsiness may be present during stage W and may persist into stage N1.
2. In stage W, the majority of individuals with eyes closed will demonstrate alpha rhythm. The EEG pattern with eyes open consists of low amplitude activity (chiefly beta and alpha frequencies) without the rhythmicity of alpha rhythm. About 10% of subjects do not generate alpha rhythm on eye closure, and a further 10% may generate limited alpha rhythm. In these subjects, the occipital EEG activity is similar during eye opening and eye closure.
3. The EOG during wakefulness may demonstrate rapid eye blinks at a frequency of about 0.5-2 Hz. As drowsiness develops, the frequency of blinking slows, and eye blinks may be replaced by slow eye movements, even in the presence of continued alpha rhythm. If the eyes are open, voluntary rapid eye movements or reading eye movements may be seen.
4. The chin EMG during stage W is of variable amplitude, but is usually higher than during sleep stages.

### 4. STAGE N1

[RECOMMENDED]

#### Definitions

**Slow eye movements (SEM):** Conjugate, reasonably regular, sinusoidal eye movements with an initial deflection usually lasting >500 msec.

**Low amplitude, mixed frequency activity:** Low amplitude, predominantly 4-7 Hz activity.

**Vertex sharp waves (V waves):** Sharply contoured waves with duration <0.5 seconds maximal over the central region and distinguishable from the background activity.

**Sleep onset:** The start of the first epoch scored as any stage other than stage W. (In most subjects this will usually be the first epoch of stage N1.)

#### Rules

**A. In subjects who generate alpha rhythm, score stage N1 if alpha rhythm is attenuated and replaced by low amplitude, mixed frequency activity for more than 50% of the epoch.**

**B. In subjects who do not generate alpha rhythm, score stage N1 commencing with the earliest of any of the following phenomena:**

- 1) Activity in range of 4-7 Hz with slowing of background frequencies by  $\geq 1$  Hz from those of stage W.
- 2) Vertex sharp waves.
- 3) Slow eye movements.

#### Notes:

1. Vertex sharp waves may be present but are not required for scoring stage N1.
2. The EOG will often show slow eye movement in stage N1, but these are not required for scoring.
3. During stage N1, the chin EMG amplitude is variable, but often lower than in stage W.
4. As slow eye movements often commence before attenuation of alpha rhythm, sleep latency may be slightly shorter for some individuals who do not generate alpha rhythm compared to those who do.

## 5. STAGE N2

[RECOMMENDED]

### Definitions

**K complex:** A well-delineated negative sharp wave immediately followed by a positive component standing out from the background EEG, with total duration  $\geq 0.5$  seconds, usually maximal in amplitude when recorded using frontal derivations. For an arousal to be associated with a K complex, it must commence no more than 1 second after termination of the K complex.

**Sleep spindle:** A train of distinct waves with frequency 11-16 Hz (most commonly 12-14 Hz) with a duration  $\geq 0.5$  seconds, usually maximal in amplitude using central derivations.

### Rules

#### A. The following rule defines the start of a period of stage N2 sleep:

1) Begin scoring stage N2 (in absence of criteria for N3) if 1 or both of the following occur during the first half of that epoch or the last half of the previous epoch:

- a. One or more K complexes unassociated with arousals
- b. One or more trains of sleep spindles

Note:

1. Continue to score stage N1 for epochs with arousal-associated K complexes but no spontaneous K complexes or sleep spindles.
2. For the purposes of scoring N2 sleep, arousals are defined according to arousal rule V.l.

#### B. The following rule defines continuation of a period of stage N2 sleep:

1) Continue to score epochs with low amplitude, mixed frequency EEG activity without K complexes or sleep spindles as stage N2 if they are preceded by a) K complexes unassociated with arousals or b) sleep spindles.

#### C. The following rule defines the end of a period of stage N2 sleep.

1) End stage N2 sleep when 1 of the following events occurs:

- a. Transition to stage W
- b. An arousal (change to stage N1 until a K complex unassociated with an arousal or a sleep spindle occurs) (See Figure 1)
- c. A major body movement followed by slow eye movements and low amplitude mixed frequency EEG without non-arousal associated K complexes or sleep spindles (score the epoch following the major body movement as stage N1; score the epoch as stage N2 if there are no slow eye movements; the epoch containing the body movement is scored using criteria in Section 8) (See Figure 2)
- d. Transition to stage N3
- e. Transition to stage R

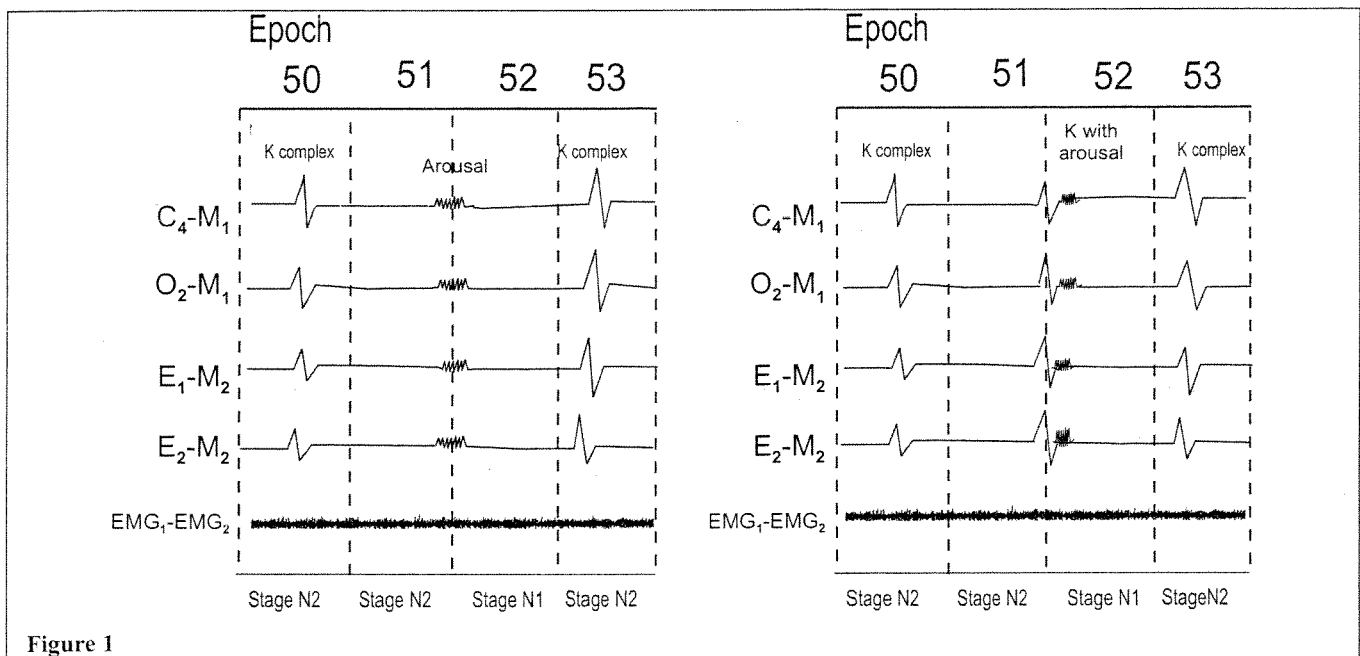

Figure 1

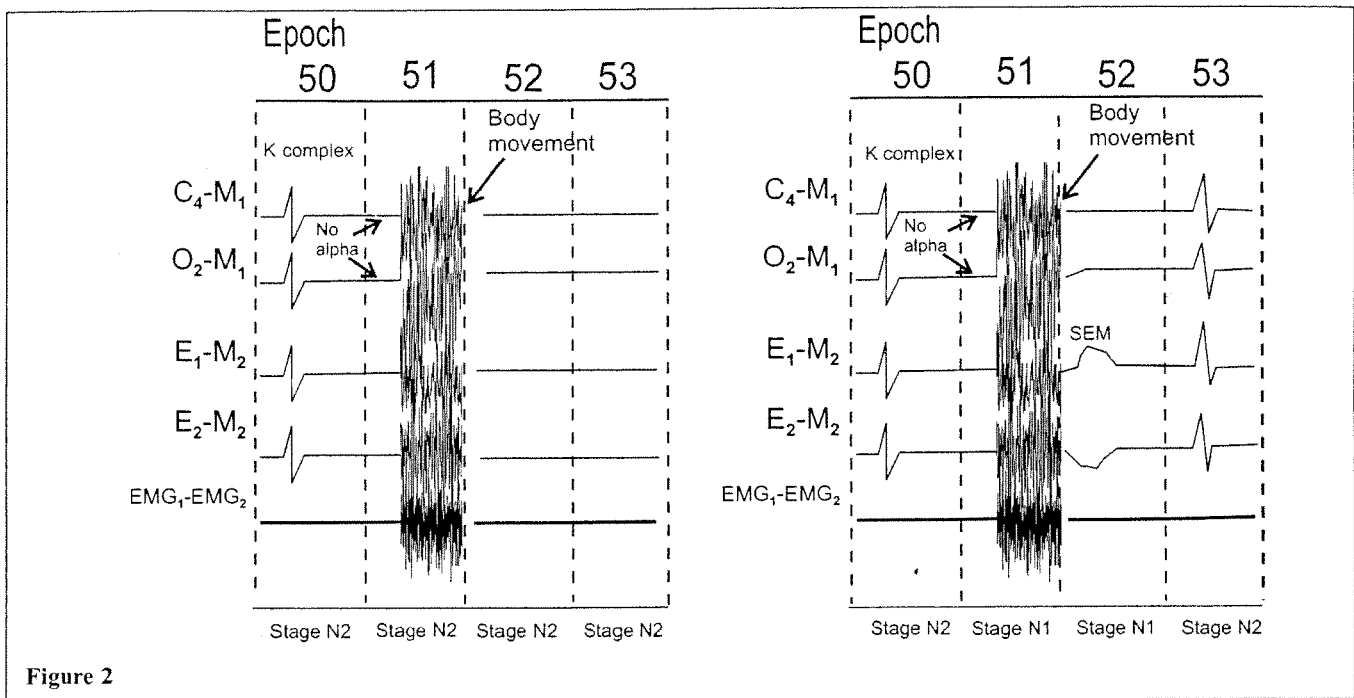

Figure 2

Notes:

1. The EOG usually shows no eye movement activity during stage N2 sleep, but slow eye movements may persist in some subjects.
2. In stage N2, the chin EMG is of variable amplitude, but is usually lower than in stage W, and may be as low as in stage R sleep.

## 6. STAGE N3

[RECOMMENDED]

### Definition

**Slow wave activity:** Waves of frequency 0.5 Hz-2 Hz and peak-to-peak amplitude  $>75 \mu\text{V}$ , measured over the frontal regions.

### Rule

A. Score stage N3 when 20% or more of an epoch consists of slow wave activity, irrespective of age.

Notes:

1. Sleep spindles may persist in stage N3 sleep.
2. Eye movements are not typically seen during stage N3 sleep.
3. In stage N3, the chin EMG is of variable amplitude, often lower than in stage N2 sleep and sometimes as low as in stage R sleep.

## 7. STAGE R

[RECOMMENDED]

### Definitions

**Rapid eye movements (REM):** Conjugate, irregular, sharply peaked eye movements with an initial deflection usually lasting  $<500$  msec.

**Low chin EMG tone:** Baseline EMG activity in the chin derivation no higher than in any other sleep stage and usually at the lowest level of the entire recording.

**Sawtooth waves:** Trains of sharply contoured or triangular, often serrated, 2-6 Hz waves maximal in amplitude over the central head regions and often, but not always, preceding a burst of rapid eye movements.

**Transient muscle activity:** Short irregular bursts of EMG activity usually with duration  $<0.25$  seconds superimposed on low EMG tone. The activity may be seen in the chin or anterior tibial EMG derivations, as well as in EEG or EOG derivations, the latter indicating activity of cranial nerve innervated muscles. The activity is maximal in association with rapid eye movements.

### Rules

A. Score stage R sleep in epochs with all the following phenomena:

- a. Low amplitude, mixed frequency EEG
- b. Low chin EMG tone
- c. Rapid eye movements

**B. The following rule defines the continuation of a period of stage R sleep:**

Continue to score stage R sleep, even in the absence of rapid eye movements, for epochs following 1 or more epochs of stage R as defined in A above, if the EEG continues to show low amplitude, mixed frequency activity without K complexes or sleep spindles and the chin EMG tone remains low. (Figure 3)

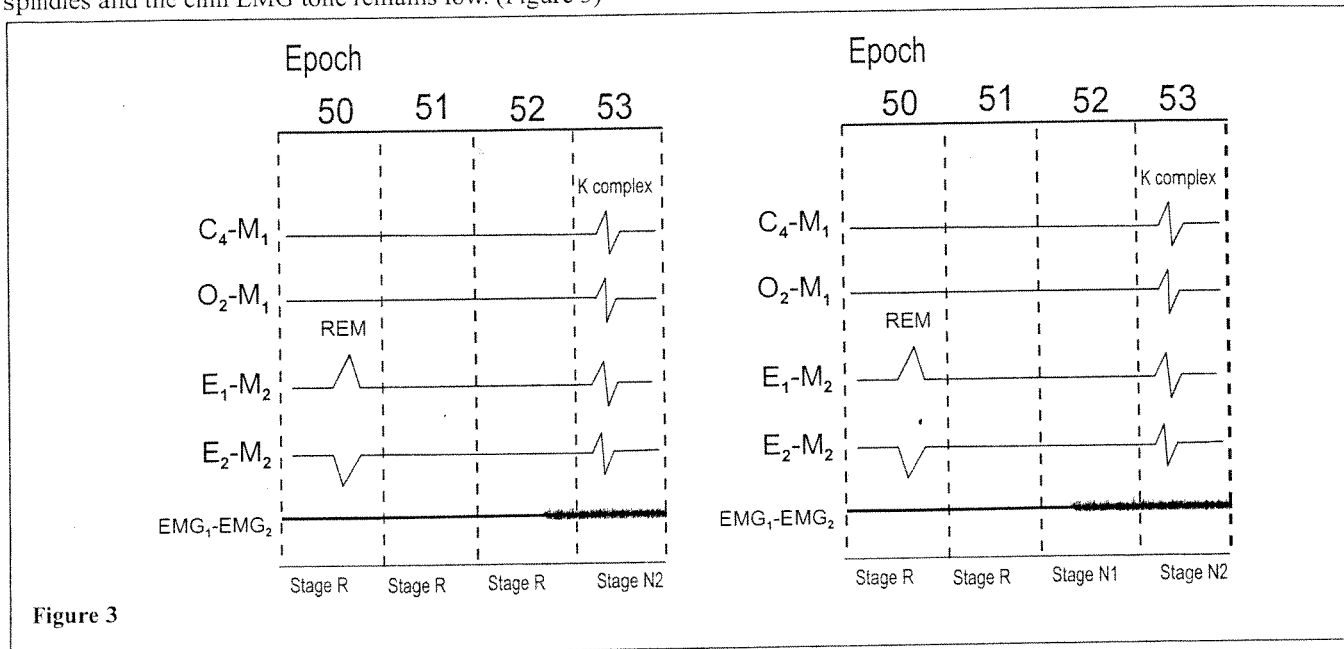

Figure 3

**C. The following rule defines the end of a period of stage R sleep:**

- 1) Stop scoring stage R sleep when 1 or more of the following occur:
  - a. There is a transition to stage W or N3
  - b. An increase in chin EMG tone above the level of stage R is seen and criteria for stage N1 are met (Figure 4)
  - c. An arousal occurs followed by low amplitude, mixed frequency EEG and slow eye movements (score as stage N1; if no slow eye movements and chin EMG tone remains low, continue to score as stage R) (Figure 5)
  - d. A major body movement followed by slow eye movements and low amplitude mixed frequency EEG without non-arousal associated K complexes or sleep spindles (score the epoch following the major body movement as stage N1; if no slow eye movements and the EMG tone remains low, continue to score as stage R; the epoch containing the body movement is scored using criteria in Section 8) (Figure 6)
  - e. One or more non-arousal associated K complexes or sleep spindles are present in the first half of the epoch in the absence of rapid eye movements, even if chin EMG tone remains low (score as stage N2) (Figure 7)

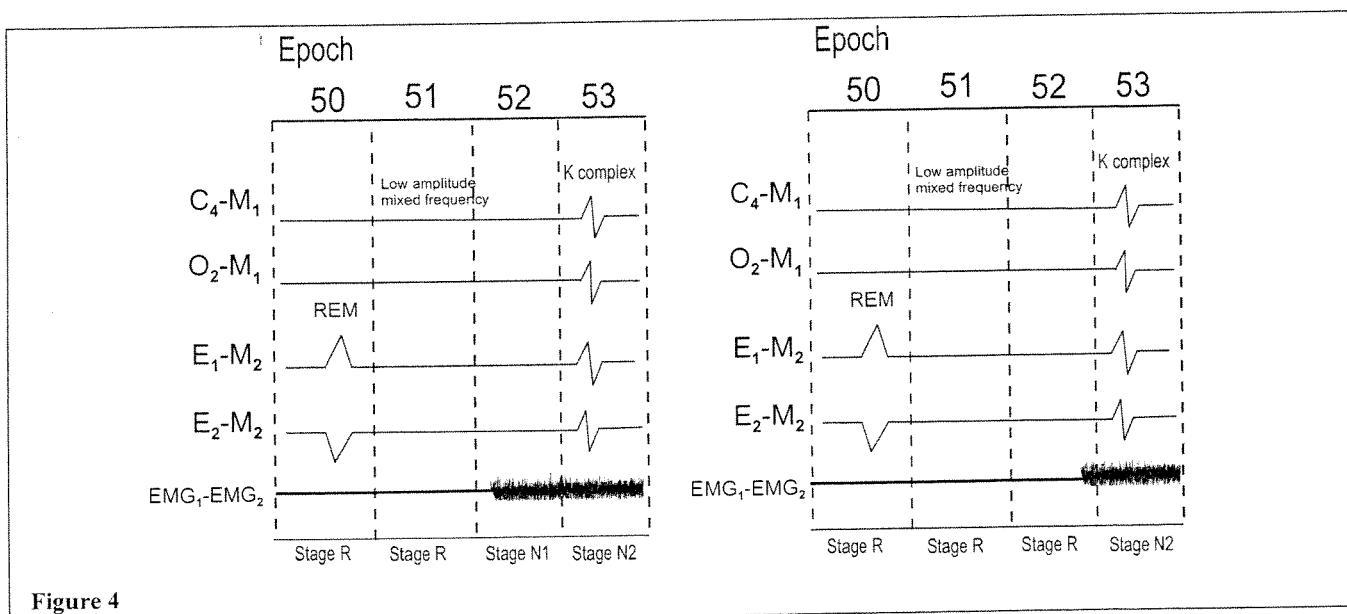

Figure 4

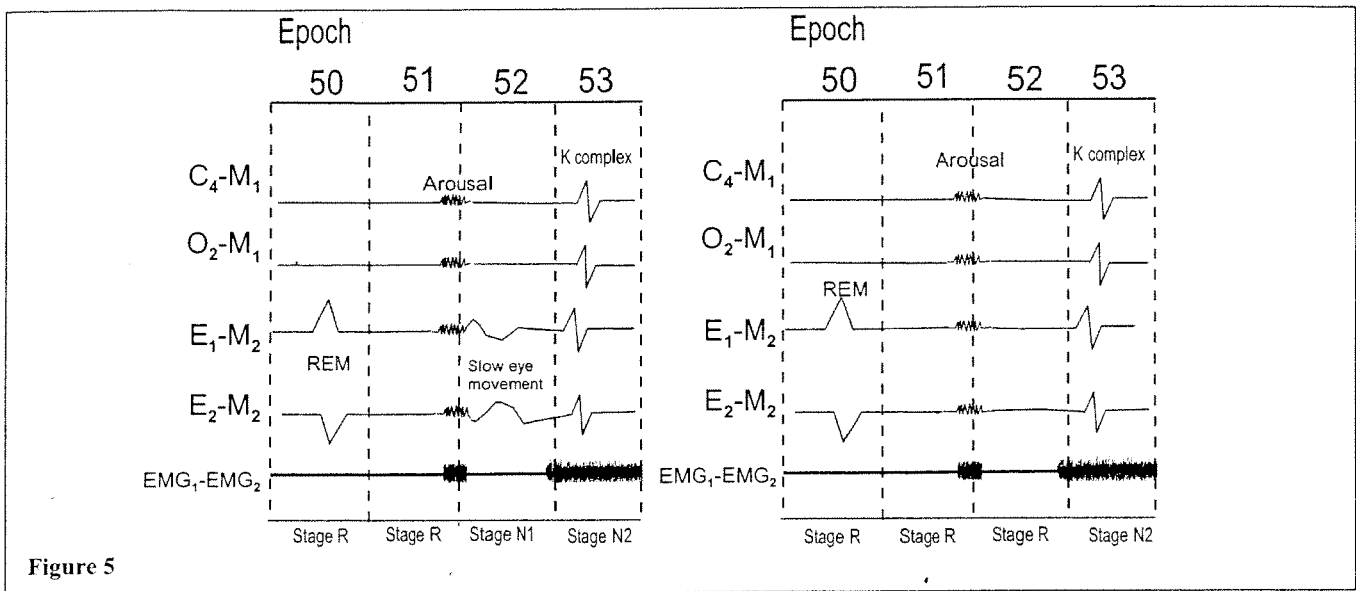

Figure 5

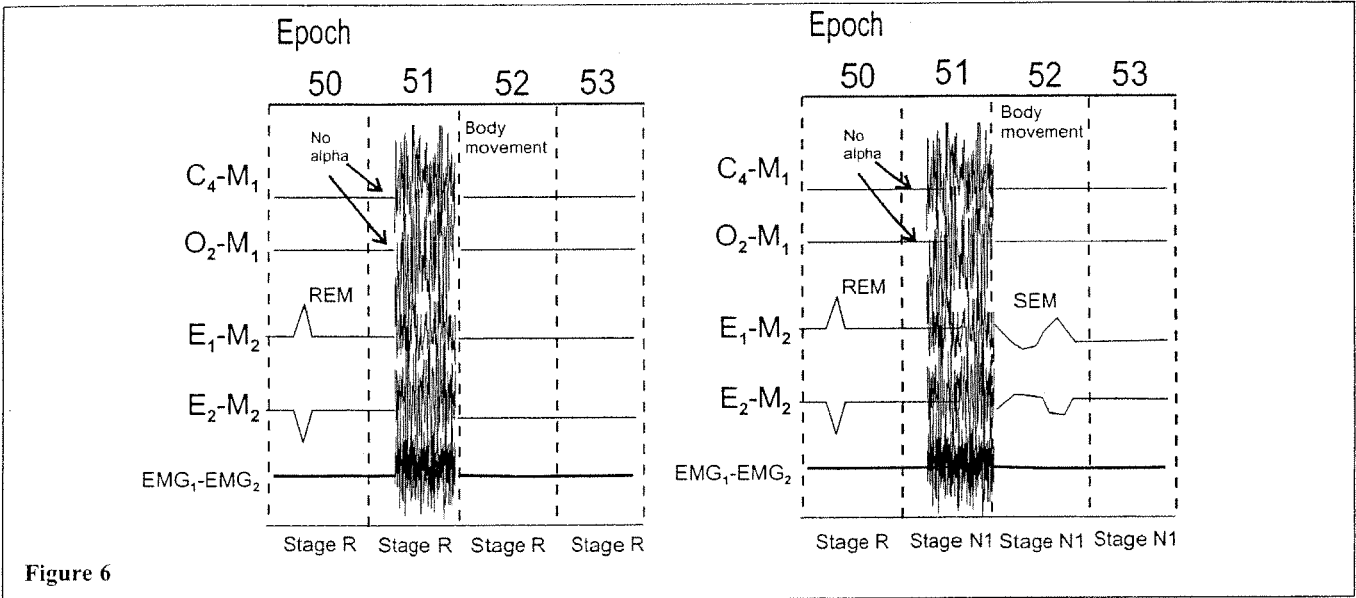

Figure 6

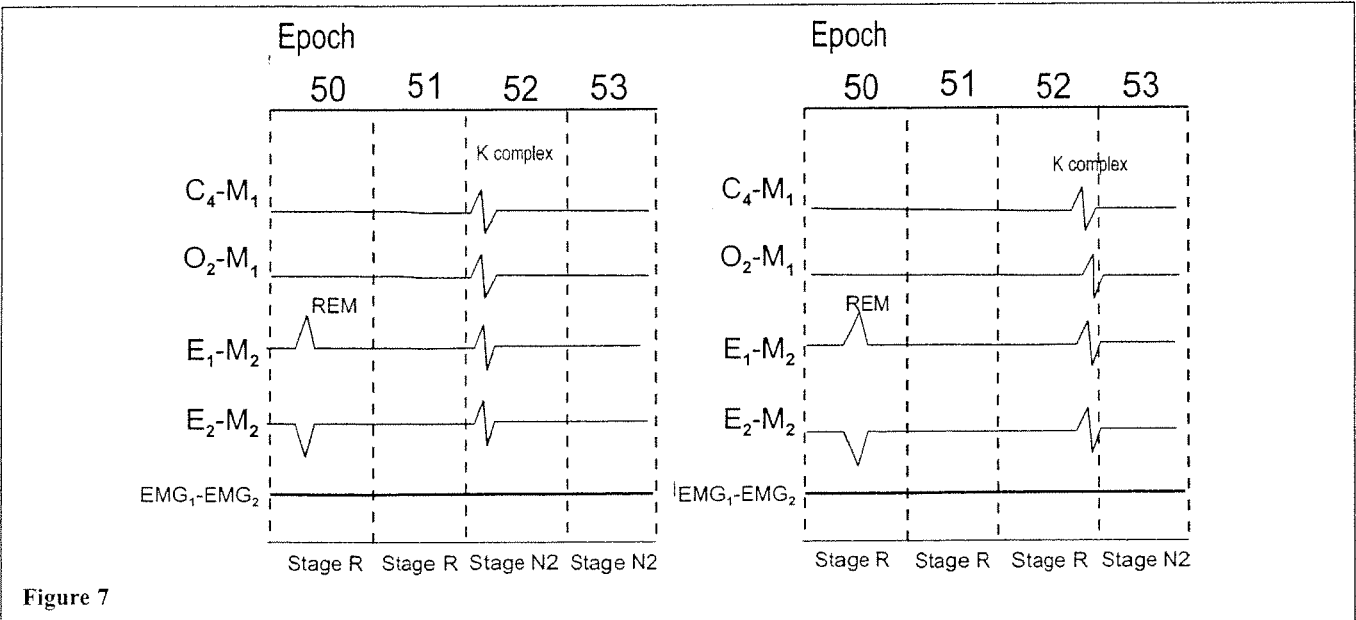

Figure 7



**D. Score epochs at the transition between stage N2 and stage R as follows:**

- 1) In between epochs of definite stage N2 and definite stage R, score an epoch with a distinct drop in chin EMG in the first half of the epoch to the level seen in stage R as stage R if all of the following criteria are met, even in the absence of rapid eye movements (Figure 8):
  - a. Absence of non-arousal associated K complexes
  - b. Absence of sleep spindles
- 2) In between epochs of definite stage N2 and definite stage R, score an epoch with a distinct drop in chin EMG in the first half of the epoch to the level seen in stage R as stage N2 if all of the following criteria are met (Figure 9A):
  - a. Presence of non-arousal associated K complexes or sleep spindles
  - b. Absence of rapid eye movements
- 3) In between epochs of definite stage N2 with minimal chin EMG tone and definite stage R without further drop in chin EMG tone, score epochs as stage R if all of the following are met, even in the absence of rapid eye movements (Figure 9B):
  - a. Absence of non-arousal associated K complexes
  - b. Absence of sleep spindles

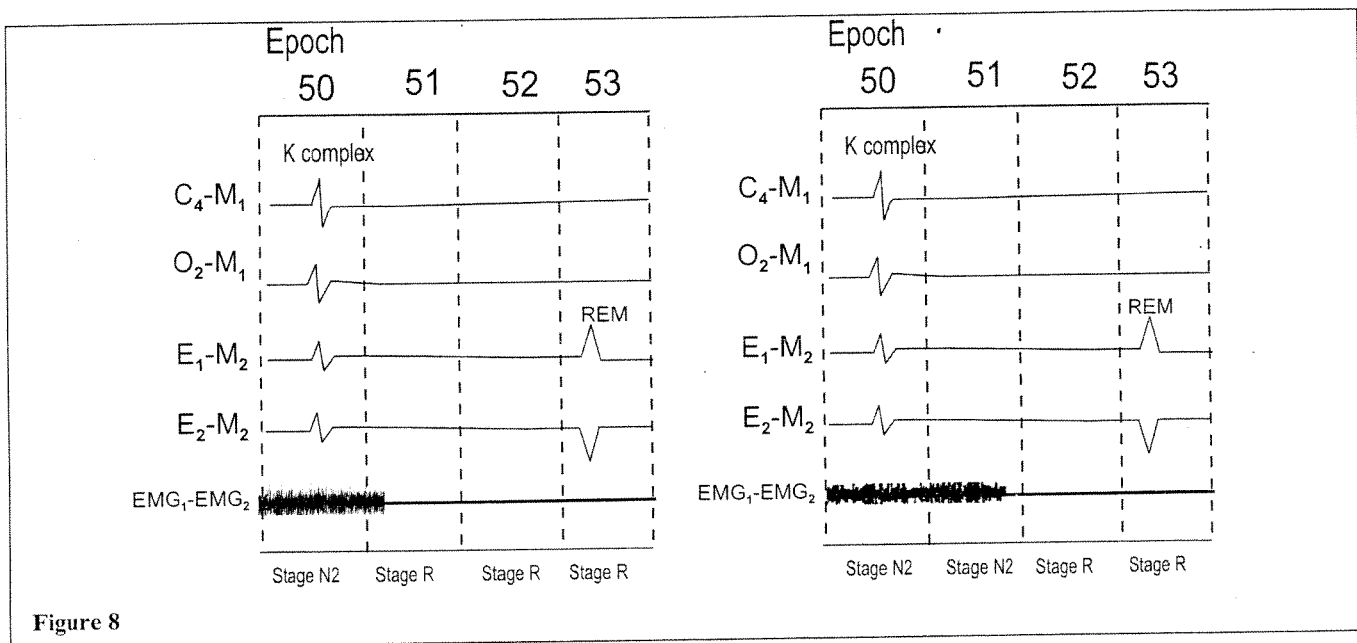

Figure 8

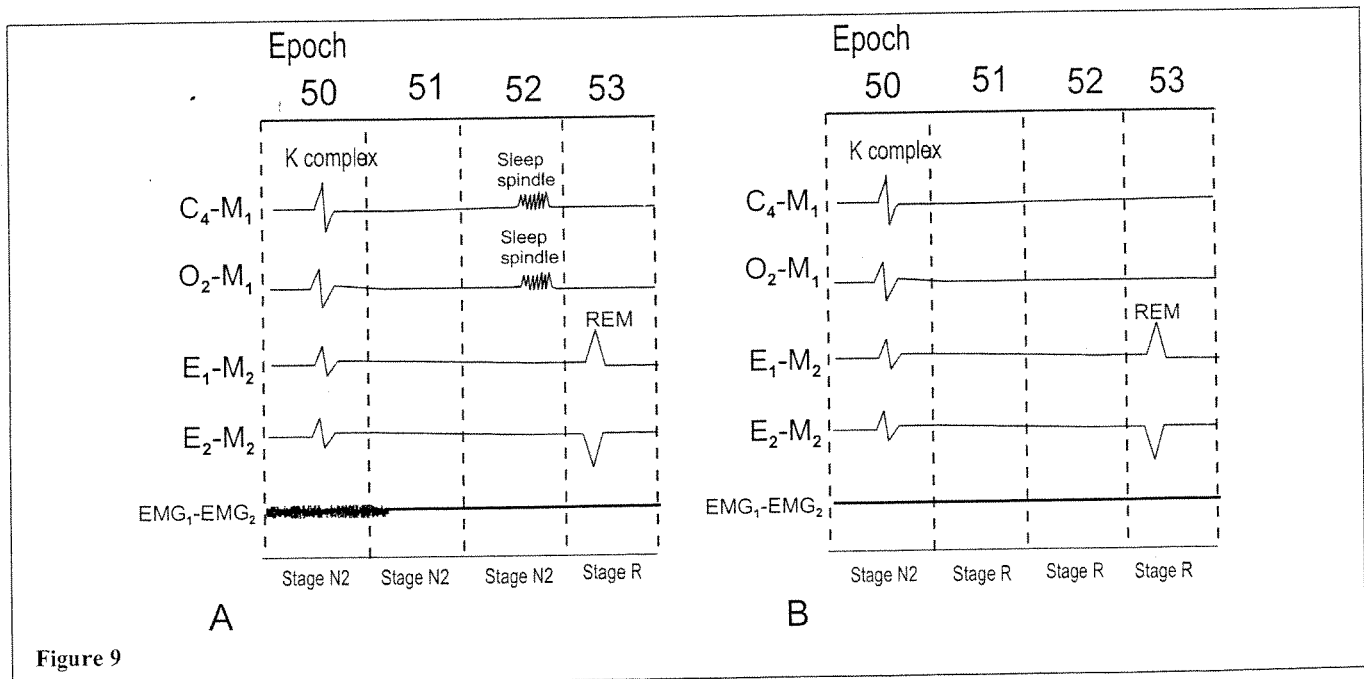

Figure 9

*Notes:*

1. *Low amplitude, mixed frequency activity in stage R resembles that seen in stage N1. In some individuals, a greater amount of alpha activity can be seen in stage R than in stage N1. The alpha frequency in stage R often is 1-2 Hz slower than during wakefulness.*
2. *The following phenomena are strongly supportive of the presence of stage R sleep and may be helpful when the stage is in doubt:*
  - a. *Sawtooth waves*
  - b. *Transient muscle activity (Sawtooth waves and transient muscle activity may be present but are not required for scoring stage R.)*
3. *At times, especially in the first REM sleep period of the night, K complexes or sleep spindles may be interspersed among epochs of what otherwise appears to be stage R sleep. The above rules indicate that epochs with rapid eye movements should be scored as stage R even in the presence of K complexes or spindles. However, if rapid eye movements are absent, subsequent epochs with K complexes or spindles should be scored as stage N2, even if chin muscle tone remains low.*

## 8. MAJOR BODY MOVEMENTS

[RECOMMENDED]

### Definition

**Major body movement:** Movement and muscle artifact obscuring the EEG for more than half an epoch to the extent that the sleep stage cannot be determined

### Rules

Score an epoch with a major body movement as follows:

- A. **If alpha rhythm is present for part of the epoch (even <15 seconds duration), score as stage W.**
- B. **If no alpha rhythm is discernable, but an epoch scorable as stage W either precedes or follows the epoch with a major body movement, score as stage W.**
- C. **Otherwise, score the epoch as the same stage as the epoch that follows it.**

## VISUAL RULES FOR CHILDREN

### 1. AGES FOR WHICH PEDIATRIC SLEEP SCORING APPLY:

[RECOMMENDED]

A. Pediatric sleep scoring rules can be used to score sleep and wakefulness in children 2 months post-term or older.

#### Notes:

1. For children less than 2 months post-term, refer to discussion in the Pediatric Task Force review paper.
2. There is no precise upper age boundary for pediatric visual rules; refer to discussion in the Pediatric Task Force review paper.

### 2. TERMINOLOGY OF SLEEP STAGES

[RECOMMENDED]

A. The following terminology should be used when scoring sleep in children 2 months post-term or older:

- 1) Stage W (Wakefulness)
- 2) Stage N1 (NREM 1)
- 3) Stage N2 (NREM 2)
- 4) Stage N3 (NREM 3)
- 5) Stage N (NREM)
- 6) Stage R (REM)

### 3. TECHNICAL CONSIDERATIONS

See adult sleep scoring rules and digital PSG section for technical considerations other than those in the notes below.

#### Notes:

1. Adult electrode derivations for EEG, EOG and chin EMG are acceptable for recording sleep except that the distance between the chin EMG electrodes often needs to be reduced from 2 cm to 1 cm and the distance from the eyes in EOG electrodes often need to be reduced from 1 cm to 0.5 cm in children and infants with small head size.
2. An initial EEG sensitivity of 7  $\mu\text{V}/\text{mm}$  (vertical scaling) is appropriate for routine PSG recordings but the sensitivity often needs to be adjusted in infants and younger children typically to 10 or even 15  $\mu\text{V}/\text{mm}$ . If sensitivities of 10 or 15  $\mu\text{V}/\text{mm}$  are used, portions of the sleep recording should be reviewed using 7  $\mu\text{V}/\text{mm}$  in order to display and recognize low voltage faster frequencies (including spindle frequencies).

### 4. SCORING SLEEP STAGES

[RECOMMENDED]

Because of the variability of sleep in infants, 4 possible scenarios are described below:

- A. If all epochs of NREM sleep contain no recognizable sleep spindles, K complexes or high-amplitude 0.5 to 2 Hz slow wave activity, score all epochs of NREM sleep as stage N (NREM).
- B. If some epochs of NREM sleep contain sleep spindles or K complexes, score those as stage N2 (NREM 2). If in the remaining NREM epochs, there is no slow wave activity comprising more than 20% of the duration of epochs, score as stage N (NREM).
- C. If some epochs of NREM sleep contain greater than 20% slow wave activity, score these as stage N3 (NREM 3). If in the remaining NREM epochs, there are no K complexes or spindles then score as stage N (NREM).
- D. If NREM is sufficiently developed that some epochs contain sleep spindles or K complexes and other epochs contain sufficient amounts of slow wave activity, then score NREM sleep in this infant as either stage N1, N2 or N3 as in an older child or adult.

#### Notes:

1. Sleep spindles usually are present in NREM sleep of infants 2 to 3 months post-term or older.
2. K complexes are usually present in NREM sleep in infants 4 to 6 months post-term or older.
3. Slow wave activity ( $\geq 75 \mu\text{V}$ , 0.5-2 Hz typically in the frontal regions) is usually present 4 to 5 months post-term.
4. NREM sleep can be scored as stage N1, N2 or N3 in most infants 5-6 months post-term or older, occasionally in infants as young as 4 to 4.5 months post-term.
5. Non-EEG correlates are very helpful in recognizing NREM and REM sleep in infants 6 months post-term or younger. These correlates in REM sleep include the presence of irregular respiration, chin EMG atonia, transient muscle activity, and rapid eye movements. In NREM sleep, correlates include regular respiration, no or rare vertical eye movements, and preserved chin EMG tone.

## 5. STAGE W [RECOMMENDED]

### Definitions

**Alpha rhythm:** Trains of sinusoidal 8-13 Hz activity recorded over the occipital region present with eye closure and which is reactive (attenuates with eye opening).

**Eye blinks:** Conjugate vertical eye movements at a frequency of 0.5-2 Hz present in wakefulness with eyes open or closed.

**Reading eye movements :** Trains of conjugate eye movements consisting of a slow phase followed by a rapid phase in the opposite direction as the child reads or visually scans the environment.

**Rapid eye movements (REM):** Conjugate, irregular, sharply peaked eye movements with an initial deflection usually lasting <500 msec. While rapid eye movements are characteristic of stage R sleep, they may also be seen in wakefulness with eyes open when subjects visually scan the environment.

**Dominant posterior rhythm (DPR):** The dominant reactive EEG rhythm over the occipital regions in relaxed wakefulness with eyes closed which is slower in infants and young children and attenuates with eye opening or attention. Frequency is 3.5-4.5 Hz when first seen in infants 3-4 months post-term, 5-6 Hz by 5-6 months, and 7.5 to 9.5 Hz by 3 years of age and amplitude is usually >50  $\mu$ V.

### Rules

**A.** In children the dominant posterior rhythm replaces the term alpha rhythm for the purposes of scoring wakefulness and NREM stages.

**B.** Score epochs as stage W when more than 50% of the epoch has either reactive alpha or age-appropriate dominant posterior rhythm over the occipital region.

**C.** If there is no discernable reactive alpha or no age-appropriate dominant posterior rhythm, score epochs as stage W if any of the following are present:

- 1) Eye blinks at a frequency of 0.5-2 Hz
- 2) Reading eye movements
- 3) Irregular conjugate rapid eye movements associated with normal or high chin muscle tone

### Notes:

1. *The dominant posterior rhythm (DPR) over the occipital derivations in adults has amplitude of <50  $\mu$ V, a frequency of 8.5 to 13 Hz, and is reactive to eye opening. The frequency and amplitude of the dominant posterior rhythm over the occipital derivations in children changes with age.*
  - a. *Only slow irregular potential changes are seen over the occipital scalp regions in infants before 3 to 4 months post-term.*
  - b. *The majority (75%) of infants by 3 to 4 months post-term have an irregular 50-100  $\mu$ V, 3.5 to 4.5 Hz activity over the occipital regions which is reactive (i.e., blocks or attenuates with eye opening and appears with passive eye closure).*
  - c. *By 5-6 months of age, many children have 50 to 110  $\mu$ V, 5-6 Hz activity over the occipital regions, and this rhythm is present in 70% of normal children by age 12 months.*
  - d. *By 3 years of age, 82% of children who were normal post-term infants show a mean occipital frequency of >8 Hz (range 7.5 to 9.5 Hz).*
  - e. *A mean alpha frequency of 9 Hz is found in 65% of 9 year olds and increases to 10 Hz in 65% by age 15.*
  - f. *The average amplitude of the dominant posterior rhythm in children is 50-60  $\mu$ V; 9% of children have >100  $\mu$ V (especially between 6-9 years); children rarely have alpha activity <30  $\mu$ V.*
2. *The highest amplitude and sharpest component of reading eye movements in children is usually surface-negative in the occipital derivations, typically last 150 to 250 msec, and have amplitudes up to 65  $\mu$ V.*
3. *Occipital sharp waves with eye blinks are typically single monophasic or biphasic <200  $\mu$ V sharp waves over the occipital derivations which usually last 200 to 400 msec and occur 100 to 500 msec following an eye blink or eye movement. In children, the initial component of the occipital sharp wave is surface-positive; the ascending phase of next surface-negative component has a steep wave front; and the descending phase of the second component less steep.*
4. *The dominant posterior rhythm (DPR) in infants and children typically contains intermixed slower EEG rhythms including:*
  - a. *Posterior slow waves of youth (PSW) which are intermittent runs of bilateral but often asymmetric 2.5-4.5 Hz slow waves superimposed, riding upon, or fused with the dominant posterior rhythm, are usually <120% of dominant posterior rhythm voltage, block with eye opening and disappear with drowsiness and sleep. PSW are uncommon in children <2 years of age, have a maximal incidence between ages 8 to 14 years, and are uncommon after age 21 years.*
  - b. *Random or semi-rhythmic occipital slowing: <100  $\mu$ V, 2.5 to 4.5 Hz rhythmic or arrhythmic activity lasting <3 seconds; a normal finding in EEGs of children ages 1 to 15 years, especially prominent ages 5 to 7 years; the amount of intermixed slowing decreases and its frequency increases with increasing age.*
5. *Spontaneous eye closure in an infant signals drowsiness.*

## 6. STAGE N1

[RECOMMENDED]

### Definitions

**Slow eye movements (SEM):** Conjugate, reasonably regular, sinusoidal eye movements with an initial deflection which usually last >500 msec.

**Low amplitude, mixed frequency activity:** Low amplitude, predominantly 4-7 Hz activity.

**Vertex sharp waves (V waves):** Sharply contoured waves with duration <0.5 seconds maximal over the central region and distinguishable from the background activity.

**Sleep onset:** The start of the first epoch scored as any stage other than stage W.

**Rhythmic anterior theta activity:** Runs of 5-7 Hz rhythmic theta activity maximal over the frontal or frontocentral regions.

**Hypnagogic hypersynchrony:** Paroxysmal bursts or runs of diffuse high amplitude sinusoidal 75 to 350  $\mu$ V, 3-4.5 Hz waves which begin abruptly, are usually widely distributed but often maximal over the central, frontal, or frontocentral scalp regions.

### Rules

**A. In subjects who generate a dominant posterior rhythm, score stage N1 if the posterior rhythm is attenuated or replaced by low amplitude mixed frequency activity for more than 50% of the epoch.**

**B. In subjects who do not generate a dominant posterior rhythm, score stage N1 commencing with the earliest of any of the following phenomena:**

- 1) Activity in the range of 4-7 Hz with slowing of background frequencies by  $\geq 1-2$  Hz from those of stage W
- 2) Slow eye movements
- 3) Vertex sharp waves
- 4) Rhythmic anterior theta activity (RAT)
- 5) Hypnagogic hypersynchrony
- 6) Diffuse or occipital predominant high amplitude rhythmic 3-5 Hz activity

### Notes:

1. Drowsiness in infants up to age 6 to 8 months is characterized by the gradual appearance of diffuse high amplitude (often 75 to 200  $\mu$ V) 3-5 Hz activity which is typically of higher amplitude, more diffuse, and 1-2 Hz slower than the waking EEG background activity.
2. Drowsiness in children 8 months to 3 years is characterized by either diffuse runs or bursts of rhythmic or semi-rhythmic bisynchronous 75 to 200  $\mu$ V, 3-4 Hz activity often maximal over the occipital regions and/or higher amplitude (>200  $\mu$ V) 4-6 Hz theta activity maximal over the frontocentral or central regions.
3. Sleep onset from 3 years on is often characterized by a 1-2 Hz slowing of the dominant posterior rhythm frequency and/or the dominant posterior rhythm often becomes diffusely distributed then is gradually replaced by relatively low voltage mixed frequency EEG activity.
4. In most subjects sleep onset will be the first epoch of stage N1 but in infants younger than 3 months post-term, this is often stage R.
5. Rhythmic anterior theta activity (RAT) are runs of moderate voltage 5-7 Hz theta activity over the frontal regions is commonly seen in adolescents and young adults when drowsy, may first appear around 5 years of age.
6. Vertex sharp waves are monophasic surface-negative sharp waves maximal over the central regions which last <0.5 second (usually <200 msec), can occur in bursts or runs, most often seen during transition to stage N1 sleep but can occur in either stage N1 or N2 sleep. By 6 months post-term, a few broad vertex sharp waves can be seen over the central regions but vertex sharp waves which resemble those seen in older children and adults typically first appear 16 months post-term.
7. Hypnagogic hypersynchrony (HH) is a distinctive EEG pattern of drowsiness and stage N1 characterized by paroxysmal runs or bursts of diffuse bisynchronous 75 to 350  $\mu$ V, 3-4.5 Hz waves often maximal over the central, frontal or frontocentral or derivations. HH often disappears with deeper stages of NREM sleep. HH is seen in approximately 30% of infants 3 months post-term, 95% of all normal children ages 6 to 8 months, and is less prevalent after age 4 to 5 years, seen in only 10% of healthy children age 11, rarely seen after age 12 years.

## 7. STAGE N2

Same as adult rules as noted in section IV. 5.

### Notes:

1. Sleep spindles (SS) are usually first seen in infants 4 to 6 weeks post-term as brief bursts of low amplitude less sinusoidal 12-14 Hz activity maximal over the vertex (C<sub>z</sub>) region, are usually well-developed and are present in all normal infants 8 to 9 weeks.
2. Eighty percent of children <13 years of age have 2 independent scalp locations and frequency ranges for sleep spindles: 10.0 to 12.75 Hz over the frontal and 12.5 to 14.75 Hz maximal over the central or centroparietal region.
3. Frontal sleep spindles are more prominent than centroparietal spindles in young children but abruptly decrease in EEG power and presence beginning at age 13 whereas centroparietal spindles persist unchanged in presence or location.
4. K complexes are usually present 5 to 6 months post-term and are maximal over the pre-frontal and frontal regions, as they are in adults. For definition, see IV.

## 8. STAGE N3

Same as adult rules in section IV. 6.

*Note: Slow wave activity (SWA) in pediatric populations often 100 to 400  $\mu$ V, 0.5 to 2.0 Hz activity maximal over the recommended derivations in the frontal scalp regions ( $F_4$ ,  $F_2$ ) first appears as early as 2 months, more often about 3 to 4.5 months post-term.*

## 9. STAGE R

Same as adult rules section IV. 7.

*Note: The continuous low voltage, mixed frequency EEG activity of stage R in infants and children resembles adults though the dominant frequencies increase with age: approximately 3 Hz activity at 7 weeks post-term; 4-5 Hz activity with bursts of saw tooth waves at 5 months; 4-6 Hz at 9 months; and prolonged runs or bursts of notched 5- to 7-Hz theta activity at 1 to 5 years age. By 5 to 10 years of age, the low voltage mixed frequency activity in stage R resembles that of adults*

## V. AROUSAL RULE

### 1. SCORING AROUSALS

[RECOMMENDED]

A. Score arousal during sleep stages N1, N2, N3, or R if there is an abrupt shift of EEG frequency including alpha, theta and/or frequencies greater than 16 Hz (but not spindles) that lasts at least 3 seconds, with at least 10 seconds of stable sleep preceding the change. Scoring of arousal during REM requires a concurrent increase in submental EMG lasting at least 1 second.

*Notes:*

1. *Arousal scoring should incorporate information from both the occipital and central derivations.*
2. *Arousal scoring can be improved by the use of additional information in the recording such as respiratory events and/or additional EEG channels. Scoring of arousals, however, cannot be based on this additional information alone and such information does not modify any of the arousal scoring rules.*

## VI. CARDIAC RULES

### 1. TECHNICAL SPECIFICATIONS

[RECOMMENDED]

A. A single modified electrocardiograph Lead II using torso electrode placement is recommended.

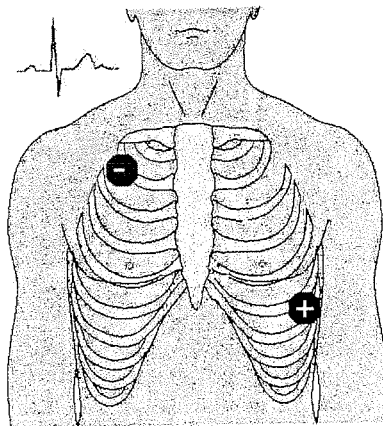

#### Notes:

1. Additional leads may be placed if clinically-indicated at the discretion of the practitioner.
2. Increasing image size on display may improve detection of arrhythmias.
3. While classically Lead II is derived from electrodes placed on the right arm and left leg, the electrodes may be placed on the torso aligned in parallel to the right shoulder and left hip.
4. Standard ECG electrode applications are superior to EEG electrodes in minimizing artifact.

### 2. SCORING RULES

[RECOMMENDED]

- A. Score sinus tachycardia during sleep for a sustained sinus heart rate of greater than 90 beats per minute for adults.
- B. Score bradycardia during sleep for a sustained heart rate of less than 40/minute for ages 6 years through adult.
- C. Score asystole for cardiac pauses greater than 3 seconds for ages 6 years through adult.
- D. Score wide complex tachycardia for a rhythm lasting a minimum of 3 consecutive beats at a rate greater than 100 per minute with QRS duration of greater than or equal to 120 msec.
- E. Score narrow complex tachycardia for a rhythm lasting a minimum of 3 consecutive beats at a rate of greater than 100 per minute with QRS duration of less than 120 msec.
- F. Score atrial fibrillation if there is an irregularly irregular ventricular rhythm associated with replacement of consistent P waves by rapid oscillations that vary in size, shape, and timing.

#### Notes:

1. Significant arrhythmias such as heart block should be reported if the quality of the single lead is sufficient for accurate scoring.
2. Ectopic beats should be reported if felt to be clinically significant.
3. Sinus rates vary according to age in children, with faster rates in young children as compared to adults. For typical sinus rates in children, refer to the Cardiac Task Force review paper.



## VII. MOVEMENT RULES

### 1. SCORING PERIODIC LIMB MOVEMENTS IN SLEEP (PLMS)

[RECOMMENDED]

#### A. The following rules define a significant leg movement (LM) event:

- 1) The minimum duration of a LM event is 0.5 seconds
- 2) The maximum duration of a LM event is 10 seconds.
- 3) The minimum amplitude of a LM event is an 8  $\mu$ V-increase in EMG voltage above resting EMG.
- 4) The timing of the onset of a LM event is defined as the point at which there is an 8  $\mu$ V-increase in EMG voltage above resting EMG.
- 5) The timing of the ending of a LM event is defined as the start of a period lasting at least 0.5 seconds during which the EMG does not exceed 2  $\mu$ V above resting EMG.

#### B. The following rules define a PLM series:

- 1) The minimum number of consecutive LM events needed to define a PLM series is 4 LMs.
- 2) The minimum period length between LMs (defined as the time between onsets of consecutive LMs) to include them as part of a PLM series is 5 seconds.
- 3) The maximum period length between LMs (defined as the time between onsets of consecutive LMs) to include them as part of a PLM series is 90 sec.
- 4) Leg movements on 2 different legs separated by less than 5 seconds between movement onsets are counted as a single leg movement.

#### Notes:

1. An LM should not be scored if it occurs during a period from 0.5 seconds preceding an apnea or hypopnea to 0.5 seconds following an apnea or hypopnea.
2. An arousal and a PLM should be considered associated with each other when there is <0.5 seconds between the end of one event and the onset of the other event regardless of which is first.
3. Surface electrodes should be placed longitudinally and symmetrically around the middle of the muscle so that they are 2 to 3 cm apart or 1/3 of the length of the anterior tibialis muscle, whichever is shorter. Both legs should be monitored for the presence of the leg movements. Separate channels for each leg are strongly preferred. Combining electrodes from the 2 legs to give 1 recorded channel may suffice for some clinical settings, though it should be recognized that this strategy may reduce the number of detected LMs. Movements of the upper limbs may be sampled if clinically indicated.
4. The rules in "A" above define a significant leg movement event by absolute increase in  $\mu$ V above resting baseline for the anterior tibialis EMG. This requires a stable resting EMG for the relaxed anterior tibialis whose absolute signal should be no greater than +10  $\mu$ V between negative and positive deflection ( $\pm 5 \mu$ V) or + 5  $\mu$ V for rectified signals.
5. Use of 60 Hz (notch) filters should be avoided. Impedances need to be less than 10,000  $\Omega$ . Less than 5,000  $\Omega$  is preferred but may be difficult to obtain. Sensitivity limits of -100 and 100  $\mu$ V (upper/lower) are preferred.

### 2. SCORING ALTERNATING LEG MUSCLE ACTIVATION (ALMA)

[OPTIONAL]

#### A. The following rules define ALMA:

- 1) The minimum number of discrete and alternating bursts of leg muscle activity needed to score an ALMA series is 4 ALMAs.
- 2) The minimum frequency of the alternating EMG bursts in ALMA is 0.5 Hz.
- 3) The maximum frequency of the alternating EMG bursts in ALMA is 3.0 Hz.

#### Notes:

1. ALMAs alternate between legs.
2. The usual range for duration of ALMA is 100-500 msec.
3. ALMA may simply be a benign movement phenomenon associated with characteristic EMG patterns as there have been no reported clinical consequences

### 3. SCORING HYPNAGOGIC FOOT TREMOR (HFT)

[OPTIONAL]

#### A. The following rules define HFT:

- 1) The minimum number of bursts needed to make a train of bursts in hypnagogic foot tremor is 4 bursts.
- 2) The minimum frequency of the EMG bursts in hypnagogic foot tremor is 0.3 Hz.
- 3) The maximum frequency of the EMG bursts in hypnagogic foot tremor is 4.0 Hz.

#### Notes:

1. The usual range for duration of hypnagogic foot tremor is 250-1000 msec.
2. HFT may simply be benign movement phenomenon associated with characteristic EMG patterns as there have been no reported clinical consequences.

### 4. SCORING EXCESSIVE FRAGMENTARY MYOCLONUS (EFM)

[OPTIONAL]

#### A. The following rules define EFM:

- 1) The usual maximum EMG burst duration seen in fragmentary myoclonus is 150 msec
- 2) At least 20 minutes of NREM sleep with EFM must be recorded
- 3) At least 5 EMG potentials per minute must be recorded

#### Notes:

1. EFM may be a benign movement phenomenon associated with a characteristic EMG pattern as there have been no reported clinical consequences.
2. In many cases no visible movements are present. Gross jerk-like movements across the joint spaces are not observed. When minor movement across a joint space is present, the movement resembles the small twitch-like movements of the fingers, toes, and the corner of the mouth intermittently seen in REM sleep in normal individuals.
3. In some cases when visible movement is present, the EMG burst duration may be >150 msec.

### 5. SCORING BRUXISM

[RECOMMENDED]

#### A. The following rules define bruxism:

- 1) Bruxism may consist of brief (phasic) or sustained (tonic) elevations of chin EMG activity that are at least twice the amplitude of background EMG.
- 2) Brief elevations of chin EMG activity are scored as bruxism if they are 0.25-2 seconds in duration and if at least 3 such elevations occur in a regular sequence.
- 3) Sustained elevations of chin EMG activity are scored as bruxism if the duration is more than 2 seconds.
- 4) A period of at least 3 seconds of stable background chin EMG must occur before a new episode of bruxism can be scored.
- 5) Bruxism can be scored reliably by audio in combination with polysomnography by a minimum of 2 audible tooth grinding episodes/night of polysomnography in the absence of epilepsy.

#### Notes:

1. In sleep, jaw contraction frequently occurs. This contraction can take 2 forms: a) sustained (tonic) jaw clenching tonic contractions or b) a series of repetitive brief (phasic) muscle contractions termed rhythmic masticatory muscle activity (RMMA).
2. In addition to the recommended placement of chin EMG electrodes as noted in section IV.A.1.c, additional masseter electrodes may be placed at the discretion of the investigator or clinician.

### 6. SCORING PSG FEATURES OF REM SLEEP BEHAVIOR DISORDER (RBD):

[RECOMMENDED]

#### Definitions

**Sustained muscle activity (tonic activity) in REM sleep:** An epoch of REM sleep with at least 50% of the duration of the epoch having a chin EMG amplitude greater than the minimum amplitude than in NREM.

**Excessive transient muscle activity (phasic activity) in REM sleep:** In a 30-second epoch of REM sleep divided into 10 sequential 3 second mini-epochs, at least 5 (50%) of the mini-epochs contain bursts of transient muscle activity. In RBD, excessive transient muscle activity bursts are 0.1 – 5.0 seconds in duration and at least 4 times as high in amplitude as the background EMG activity.

#### Rule:

- 1) The polysomnographic characteristics of RBD are characterized by either or both of the following features:
  - a. Sustained muscle activity in REM sleep in the chin EMG
  - b. Excessive transient muscle activity during REM in the chin or limb EMG

*Notes:*

1. *Time synchronized video PSG audio or a characteristic clinical history are necessary to make the diagnosis of RBD in addition to polysomnographic evidence of REM without atonia or excessive transient muscle activity in REM.*
2. *Transient muscle activity and occasional accompanying visible twitching of small muscle groups are a normal phenomenon seen in REM sleep (see IV. Adult. 7). When larger muscle groups are involved, this activity is not associated with large, overt muscular activity acting across large joints. When smaller muscle groups are involved, the movement often involves the distal muscles of the hands and face or the corners of the mouth. Transient muscle activity may be excessive in RBD.*
3. *The sustained muscle activity or the excessive transient muscle activity observed in REM sleep may be interrupted by superimposed (usually dream-enacting) behaviors of RBD.*
4. *In normal individuals there is an atonia seen in REM sleep in the chin and anterior tibialis EMG. In this state the baseline amplitude of the EMG signal decreases markedly. This atonia of REM sleep is lost to a considerable extent in RBD, with variable frequency, and as a result, the EMG baseline amplitude is often higher. In this situation, the EMG can be said to be in a tonic rather than atonic state.*

## **7. SCORING THE PSG FEATURES OF RHYTHMIC MOVEMENT DISORDER**

[RECOMMENDED]

### **A. The following rule defines the polysomnographic characteristics of rhythmic movement disorder:**

- 1) The minimum frequency for scoring rhythmic movements is 0.5 Hz
- 2) The maximum frequency for scoring rhythmic movements is 2.0 Hz
- 3) The minimum number of individual movements required to make a cluster of rhythmic movements is 4 movements
- 4) The minimum amplitude of an individual rhythmic burst is 2 times the background EMG activity

*Notes:*

1. *Bipolar surface electrodes should be placed to record electrical activity of the large muscle groups involved.*
2. *Time synchronized video PSG, in addition to polysomnographic criteria, is necessary to make the diagnosis of rhythmic movement disorder.*

## VIII. RESPIRATORY RULES

### RESPIRATORY RULES FOR ADULTS

#### 1. TECHNICAL CONSIDERATIONS

[RECOMMENDED]

- A. The sensor to detect absence of airflow for identification of an apnea is an oronasal thermal sensor.
- B. The sensor for detection of airflow for identification of a hypopnea is a nasal air pressure transducer with or without square root transformation of the signal.
- C. The sensor for detection of respiratory effort is either esophageal manometry, or calibrated or uncalibrated inductance plethysmography.
- D. The sensor for detection of blood oxygen is pulse oximetry with a maximum acceptable signal averaging time of 3 seconds.

*Notes:*

- 1. *Alternative sensors are to be used when the signal from the recommended sensor is not reliable.*
- 2. *The alternative signal to detect absence of airflow for identification of an apnea when the thermistor signal is unreliable is a nasal air pressure transducer.*
- 3. *An alternative sensor for detection of effort is diaphragmatic/intercostal EMG.*
- 4. *For scoring of hypopnea when the nasal pressure device is not functioning, alternative sensors including uncalibrated or calibrated inductance plethysmography or an oronasal thermal sensor may be used.*
- 5. *A small bias i.e., more events in reporting hypopneas at the flow threshold recommended for scoring hypopneas ( $\leq 50\%$  of baseline), may be corrected by square root transformation.*

#### 2. EVENT DURATION RULES

[RECOMMENDED]

- A. For scoring either an apnea or a hypopnea, the event duration is measured from the nadir preceding the first breath that is clearly reduced to the beginning of the first breath that approximates the baseline breathing amplitude (see horizontal brackets, Figures 1 and 2).
- B. When baseline breathing amplitude cannot be easily determined (and when underlying breathing variability is large), events can also be terminated when either there is a clear and sustained increase in breathing amplitude, or in the case where a desaturation has occurred, there is event-associated resaturation of at least 2%.

#### 3. SCORING OF APNEAS

[RECOMMENDED]

##### A. Score an apnea when all of the following criteria are met (Figure 1):

- 1) There is a drop in the peak thermal sensor excursion by  $\geq 90\%$  of baseline
- 2) The duration of the event lasts at least 10 seconds. (see Section 2 above)
- 3) At least 90% of the event's duration meets the amplitude reduction criteria for apnea

##### B. Classify an apnea in an adult based upon inspiratory effort:

- 1) Score a respiratory event as an obstructive apnea if it meets apnea criteria and is associated with continued or increased inspiratory effort throughout the entire period of absent airflow.
- 2) Score a respiratory event as a central apnea if it meets apnea criteria and is associated with absent inspiratory effort throughout the entire period of absent airflow.
- 3) Score a respiratory event as a mixed apnea if it meets apnea criteria and is associated with absent inspiratory effort in the initial portion of the event, followed by resumption of inspiratory effort in the second portion of the event.

*Notes:*

- 1. *Identification of an apnea does not require a minimum desaturation criterion.*
- 2. *The criteria for determination of the length of an apnea are specified in Section 2.*

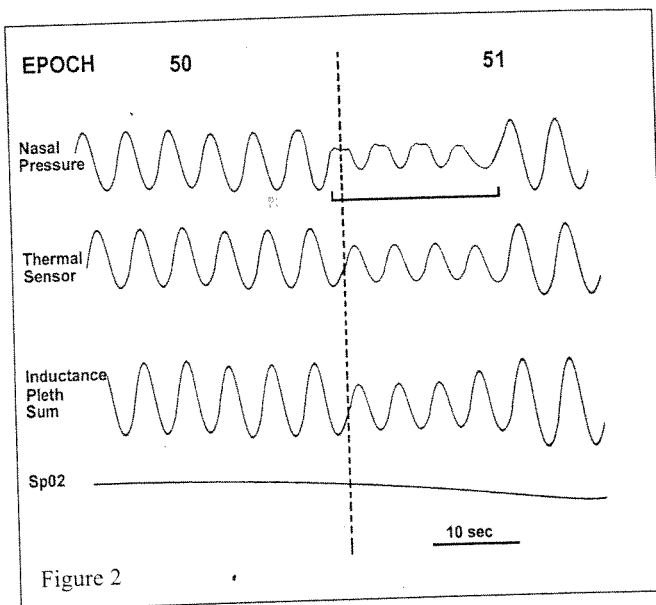
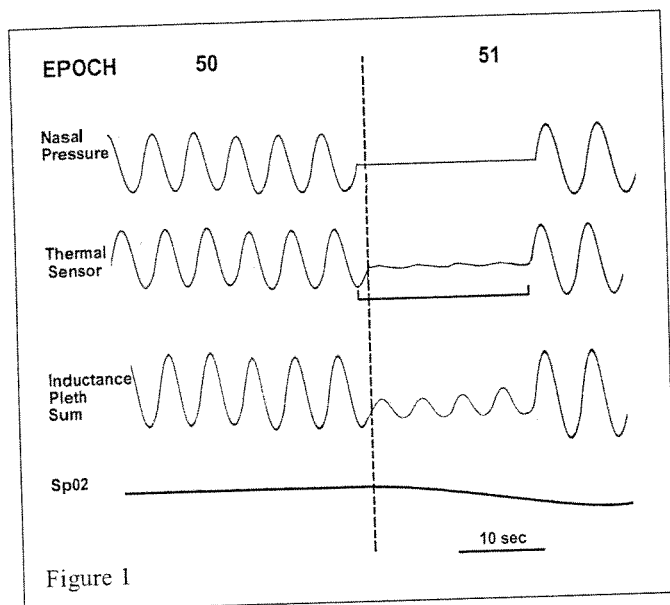

#### 4. HYPOPNEA RULES

A. Score a hypopnea if all of the following criteria are met (See Figure 2):

[RECOMMENDED]

- 1) The nasal pressure signal excursions (or those of the alternative hypopnea sensor) drop by  $\geq 30\%$  of baseline
- 2) The duration of this drop occurs for a period lasting at least 10 seconds
- 3) There is a  $\geq 4\%$  desaturation from pre-event baseline
- 4) At least 90% of the event's duration must meet the amplitude reduction of criteria for hypopnea

B. Score a hypopnea if all of the following criteria are met:

[ALTERNATIVE]

- 1) The nasal pressure signal excursions (or those of the alternative hypopnea sensor) drop by  $\geq 50\%$  of baseline
- 2) The duration of this drop occurs for a period lasting at least 10 seconds
- 3) There is a  $\geq 3\%$  desaturation from pre-event baseline or the event is associated with arousal
- 4) At least 90% of the event's duration must meet the amplitude reduction of criteria for hypopnea

Note:

1. The definition of hypopnea used (VIII.4.A or VIII.4.B) should be specified in the PSG report.
2. Classification of a hypopnea as obstructive, central, or mixed should not be performed without a quantitative assessment of ventilatory effort (esophageal manometry, calibrated respiratory inductance plethysmography, or diaphragmatic/intercostal EMG).

#### 5. RESPIRATORY EFFORT-RELATED AROUSAL RULE

A. Score a respiratory effort-related arousal (RERA) (Figure 3):

[OPTION]

- 1) If there is a sequence of breaths lasting at least 10 seconds characterized by increasing respiratory effort or flattening of the nasal pressure waveform leading to an arousal from sleep when the sequence of breaths does not meet criteria for an apnea or hypopnea.

Notes:

1. With respect to scoring a RERA, use of esophageal pressure is the preferred method of assessing change in respiratory effort, although nasal pressure and inductance plethysmography can be used.

#### 6. HYPOVENTILATION RULE

[OPTION]

A. Score hypoventilation during sleep as present if there is a  $\geq 10$  mm Hg increase in  $\text{PaCO}_2$  during sleep in comparison to an awake supine value.

Notes:

1. Persistent oxygen desaturation is not sufficient to document hypoventilation.
2. An increased  $\text{PaCO}_2$  value obtained immediately upon awakening from sleep is suggestive of sleep hypoventilation.
3. At this time, there is insufficient evidence to allow specification of sensors for direct or surrogate measures of  $\text{PaCO}_2$ . Both end-tidal

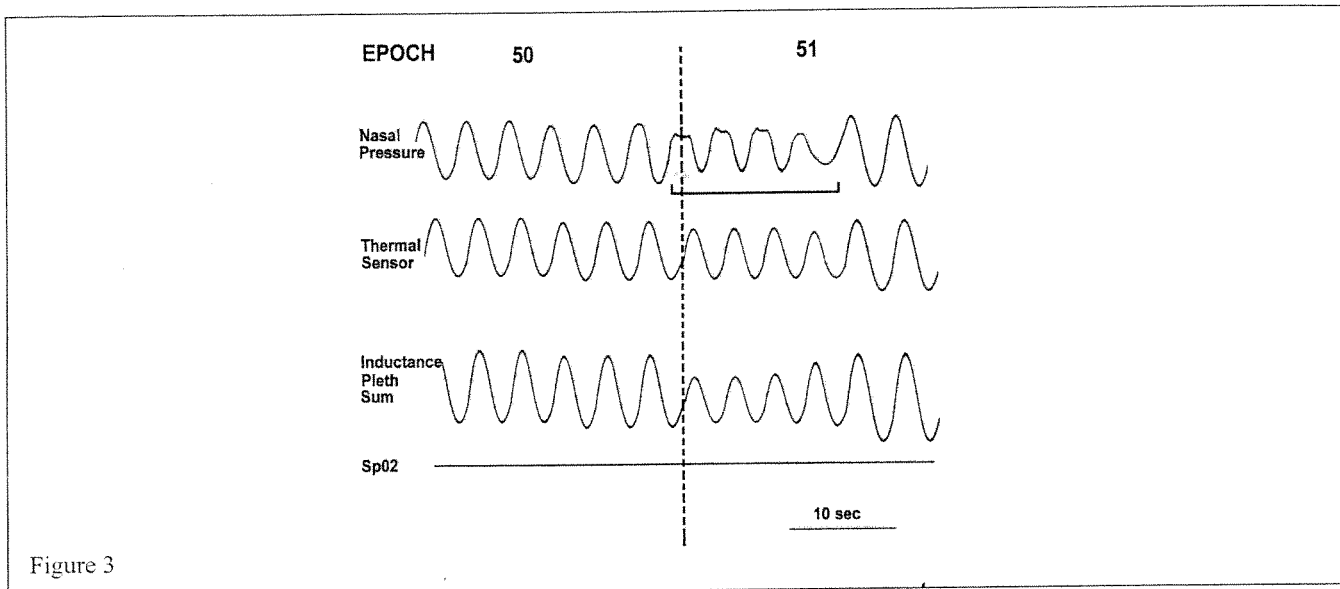

*CO<sub>2</sub> and transcutaneous CO<sub>2</sub> may be used as surrogate measures of PaCO<sub>2</sub> if there is demonstration of reliability and validity within laboratory practices.*

4. *At this time, there is insufficient evidence to allow specification of a duration of hypoventilation though the duration should be sufficient to account for the effects of response time of the sensor used and to exclude brief changes that reflect sensor artifact.*

## 7. CHEYNE STOKES BREATHING RULE

[RECOMMENDED]

A. Score Cheyne Stokes breathing if there are at least 3 consecutive cycles of cyclical crescendo and decrescendo change in breathing amplitude (Figure 4) and at least 1 of the following:

- 1) Five or more central apneas or hypopneas per hour of sleep
- 2) The cyclic crescendo and decrescendo change in breathing amplitude has duration of at least 10 consecutive minutes.

*Note: Cheyne Stokes breathing has variable cycle length that is most commonly in the range of 60 seconds.*

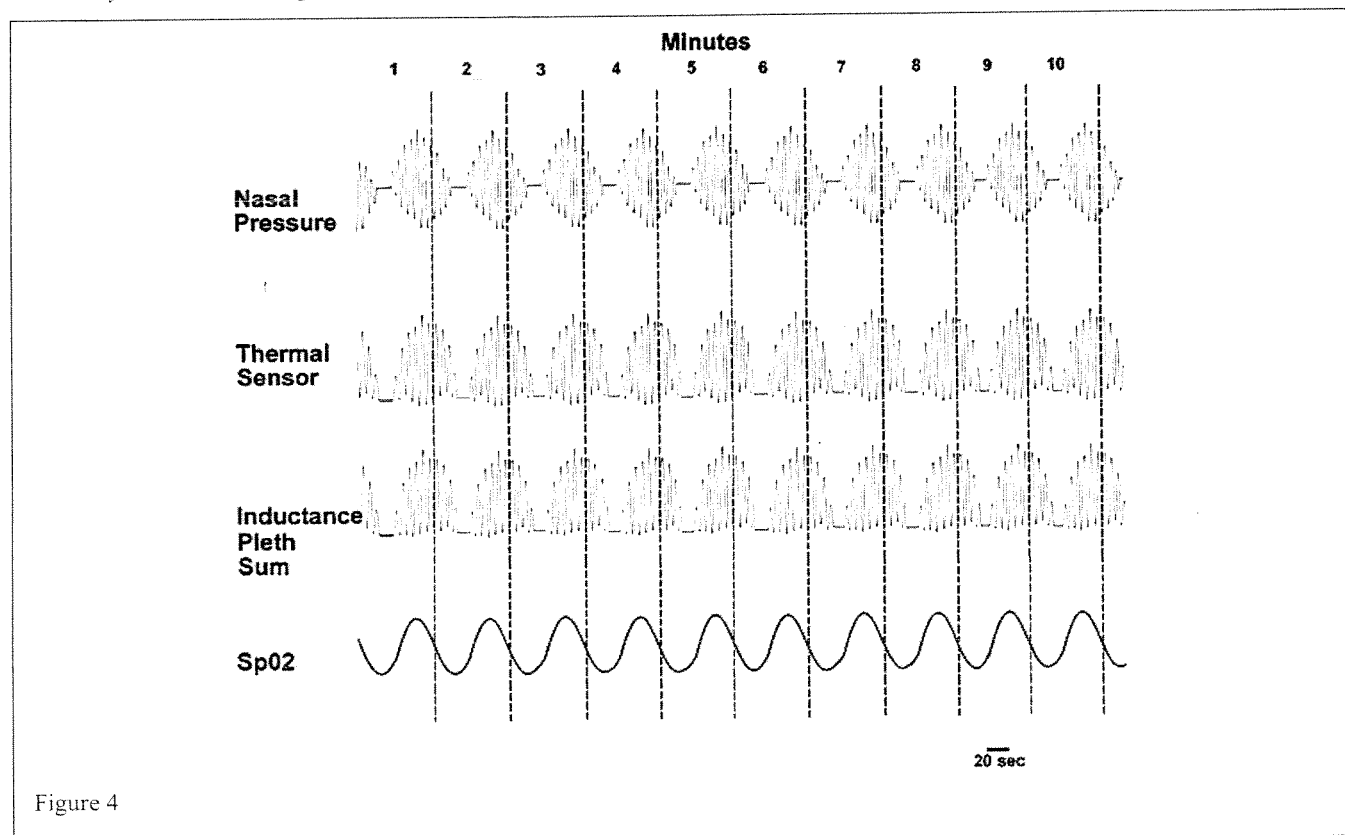

## RESPIRATORY RULES FOR CHILDREN

### 1. TECHNICAL CONSIDERATIONS

[RECOMMENDED]

- A. The sensor used to detect absence of airflow for identification of an apnea is an oronasal thermal sensor.
- B. The sensor for detection of airflow for identification of a hypopnea is a nasal air pressure transducer without square root transformation of the signal.
- C. Acceptable sensors for detection of respiratory effort are either esophageal manometry, or calibrated or uncalibrated inductance plethysmography.
- D. The sensor for detection of blood oxygen is pulse oximetry with a maximum acceptable signal averaging time of 3 seconds.
- E. Acceptable methods for assessing alveolar hypoventilation are either transcutaneous or end-tidal PCO<sub>2</sub> monitoring.

*Note:*

1. *Alternative sensors are to be used when the signal from the recommended sensor is not reliable.*
2. *The alternative signal to detect absence of airflow for identification of an apnea is a nasal air pressure transducer.*
3. *Alternative signals for identification of apnea are end-tidal PCO<sub>2</sub> and summed calibrated inductance plethysmography.*
4. *The alternative sensor for detection of airflow for identification of a hypopnea is an oronasal thermal sensor.*

### 2. AGES FOR WHICH PEDIATRIC SCORING RULES SHOULD BE USED

[RECOMMENDED]

- A. Criteria for respiratory events during sleep for infants and children can be used for children <18 years, but an individual sleep specialist can choose to score children ≥13 years using adult criteria.

*Note: Several studies have published data using pediatric criteria in children up to 18 years of age. However, there have been no studies comparing adult and pediatric criteria in adolescents, particularly those approaching adulthood. Empiric observations would suggest that adult criteria could be used in some older children.*

### 3. APNEA RULES

[RECOMMENDED]

- A. Score a respiratory event as an obstructive apnea if it meets all of the following criteria:

- 1) The event lasts for at least 2 missed breaths (or the duration of 2 breaths as determined by baseline breathing pattern)
- 2) The event is associated with a >90% fall in the signal amplitude for ≥90% of the entire respiratory event compared to the pre-event baseline amplitude
- 3) The event is associated with continued or increased inspiratory effort throughout the entire period of decreased airflow
- 4) The duration of the apnea is measured from the end of the last normal breath to the beginning of the first breath that achieves the pre-event baseline inspiratory excursion

- B. Score a respiratory event as a mixed apnea if it meets both 3.A.1, and 3.A.2, and it is associated with associated with absent inspiratory effort in the initial portion of the event, followed by resumption of inspiratory effort before the end of the event.

- C. Score a respiratory event as a central apnea if it is associated with absent inspiratory effort throughout the entire duration of the event and 1 of the following is met:

- 1) The event lasts 20 seconds or longer
- 2) The event lasts at least 2 missed breaths (or the duration of 2 breaths as determined by baseline breathing pattern) and is associated with an arousal, an awakening or a ≥3% desaturation

*Notes:*

1. *An apnea during sleep in an infant or child does not need to cause an arousal, awakening or an arterial oxygen desaturation to be scored.*
2. *A central apnea which lasts at least 2 missed breaths (or the duration of 2 breaths as determined by baseline breathing pattern), but is less than 20 seconds and immediately follows a snore, sigh, respiratory event or arousal is not scored unless it causes either an arousal, an awakening or a ≥3% desaturation.*

#### 4. PEDIATRIC HYPOPNEA RULES

[RECOMMENDED]

##### A. Score a respiratory event as a hypopnea if it meets all of the following criteria:

- 1) The event is associated with a  $\geq 50\%$  fall in the amplitude of the nasal pressure or alternative signal compared to the pre-event baseline excursion
- 2) The event lasts at least 2 missed breaths (or the duration of 2 breaths as determined by baseline breathing pattern) from the end of the last normal breathing amplitude
- 3) The fall in the nasal pressure signal amplitude must last for  $\geq 90\%$  of the entire respiratory event compared to the signal amplitude preceding the event
- 4) The event is associated with an arousal, awakening, or  $\geq 3\%$  desaturation

##### B. Score a respiratory effort related arousal (RERA) event if the conditions in either 1 or 2 are met:

- 1) When using a nasal pressure sensor all of the following must be met:
  - a. There is a discernible fall in the amplitude of signal from a nasal pressure sensor, but it is less than 50% in comparison to the baseline level
  - b. There is flattening of the nasal pressure waveform
  - c. The event is accompanied by snoring, noisy breathing, elevation in the end-tidal  $PCO_2$ , transcutaneous  $PCO_2$  or visual evidence of increased work of breathing
  - d. The duration of the event is at least 2 breath cycles (or the duration of 2 breaths as determined by baseline breathing pattern)
- 2) When using an esophageal pressure sensor all of the following must be met:
  - a. There is a progressive increase in inspiratory effort during the event
  - b. The event is accompanied by snoring, noisy breathing, elevation in the end-tidal  $PCO_2$ , transcutaneous  $PCO_2$  or visual evidence of increased work of breathing
  - c. The duration of the event is at least 2 breath cycles (or the duration of 2 breaths as determined by baseline breathing pattern)

##### Notes:

1. Removal or malfunction of the nasal pressure sensor occurs more commonly in infants and children than in adults. If this occurs during a recording, hypopneas may be scored using a thermal sensor if the signal quality is adequate, following the same criteria used for scoring hypopneas with a nasal pressure sensor.
2. A RERA (or flow limitation event) cannot be scored without an adequate nasal pressure or esophageal pressure signal.
3. Classification of a hypopnea as obstructive, central or mixed should not be performed without a quantitative assessment of ventilatory effort (esophageal manometry or calibrated respiratory inductance plethysmography).

#### 5. HYPOVENTILATION RULE

[RECOMMENDED]

##### A. Score the presence of sleep-related hypoventilation when $>25\%$ of the total sleep time as measured by either the transcutaneous $PCO_2$ and/or end-tidal $CO_2$ sensor(s) is spent with a $CO_2 > 50$ mm Hg.

##### Notes:

1. The end-tidal  $PCO_2$  often malfunctions or provides falsely low values in patients who have marked nasal obstruction, profuse nasal secretions, are obligate mouth breathers, or who are receiving supplemental oxygen or CPAP during the PSG. It is crucial to obtain a plateau in the end-tidal waveform for the signal to be considered valid.
2. Transcutaneous  $PCO_2$  monitoring provides only a semi-quantitative index of trends in alveolar ventilation, and varies unpredictably from the  $PaCO_2$  typically lagging after the event.

#### 6. PERIODIC BREATHING RULE

[RECOMMENDED]

##### A. Score periodic breathing if there are $>3$ episodes of central apnea lasting $>3$ seconds separated by no more than 20 seconds of normal breathing.